

WAPRO[®]

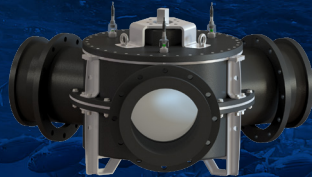
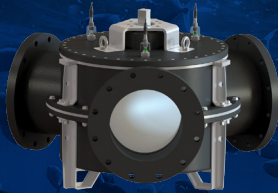
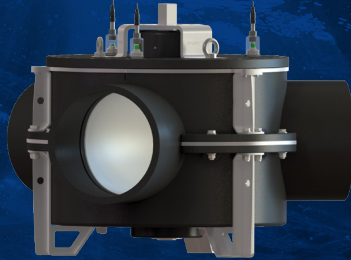

FLOW GUIDE 3-WAY-VALVE INSTALLATION MAINTENANCE & PRODUCT GUARANTEE

PLEASE NOTE SERIAL/ORDERNUMBER HERE:

**THANK YOU FOR PURCHASING A WAPRO PRODUCT.
FOR FURTHER PRODUCT INFORMATION PLEASE REFER
TO WAPRO.COM**

INDEX

SAFETY INSTRUCTIONS	3
TRANSPORT AND STORAGE	3
IDENTIFICATION	4
MOUNTING	5-6
COMMISSIONING	7
GENERAL OPERATION.....	8-9
MAINTENANCE.....	10-12
TECHNICAL INFO	13-14
WARRANTY	15

SAFETY INSTRUCTIONS

This manual should be read and properly understood before product commissioning.
All personnel working with the device must be familiar with the safety and warning instructions in this document.

STANDARDS/DIRECTIVES

Our products are designed and manufactured in compliance to recognized standards and directives.
This is certified in the Declaration of Conformity.

COMMISSIONING

Before commissioning the user need to check that the product is free of any damages obtained during transport or storage.

Prior to first use, the user needs to make sure that the steps described in the commissioning part of the manual has been followed precisely. If the device is fitted with a third-party actuator, either supplied by the manufacturer or a third party, the user needs to make sure that the setup and commissioning for that product is carried out following that device 's own specific operation instructions.

Please note that any actuator supplied by the manufacturer will not have been completely commissioned before shipping, as the setup of electrical connection and communication interface can only be performed on site. We recommend using a trained technician with knowledge of the chosen type of actuator for this task.

Commissioning is the sole responsibility of the user. The manufacturer can not be held liable for any consequential damage.

TRANSPORT AND STORAGE

TRANSPORT

The device should be kept in its original packaging during the entire transport. The shipment pallet must be kept level and securely fastened down. It is not allowed to stack other products on top of the devise during transport.

The device can only be moved on its original shipment pallet or using at least two of the nine lifting points on the outside of the device. The points are shown on the following figure.

Photo clearly marking the lifting points.

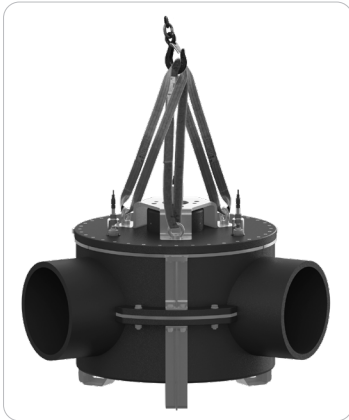

Lifting the product using any other method could result in damage to personnel or the device itself.

STORAGE

The product must be stored in a dry, well-ventilated environment, away from direct sunlight. Temperatures in storage must be between -30°C and 40°C. The surface temperature of the plastics can't exceed 80°C. The device must not be flooded or otherwise submerged in water during storage. If the device is stored outside for longer durations, it is advisable to cover up the inlet pipes to keep dirt and debris out, as well as keeping wildlife from inhabiting the valve.

In areas with high humidity or with big fluctuations in temperature, the transportation wrapping must be removed to avoid buildup of condensation. If the device has an electric actuator it is advised to hook the actuator up to mains power to allow the internal heater to keep condensation from damaging the circuit boards.

IDENTIFICATION

Do not remove the label. If purchasing spare parts, state the size and serial number.



IDENTIFICATION IF THE NAME PLATE IS MISSING

If the type plate is missing, the size of RIA Flow Guide can be identified by measuring the outer diameter of the inlet pipe.

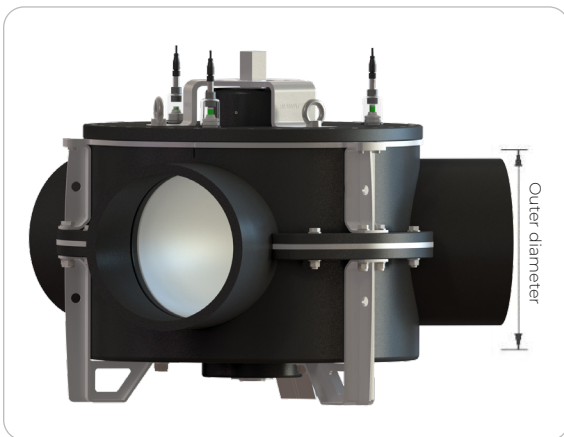

MOUNTING

This manual should be read and properly understood before mounting. All personnel working with the device must be familiar with the safety and warning instructions in this document.

MOUNTING POSITION

The product has no predetermined mounting direction and can be turned to any angle. It is not recommended to mount the device with the lid facing downwards (tilted more than 90° as seen on the figure) Any angle over 90° means that the weight of the core in unsupported during service and can fall out of the housing during gasket changes. This can result in injuries and damage to the product.

Due to this, mounting the product at an angle exceeding 90° voids the DOP compliance.

Please note that configurations supplied with electric actuators usually only has two possible positions of the core, and therefore has a specific direction for installation where one of the three pipe acts as a common inlet.

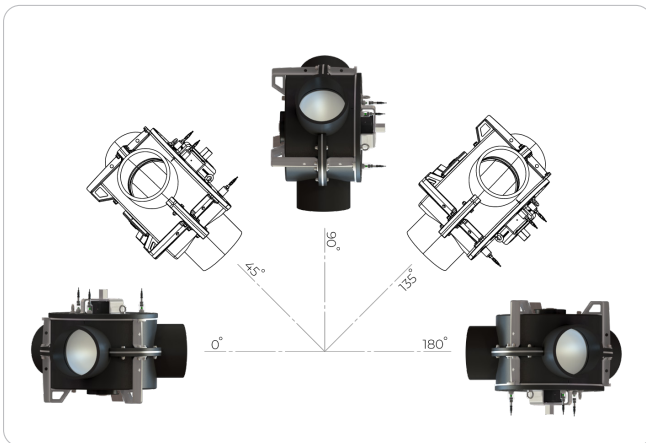

SERVICE ACCESS

To be able to perform proper repair and servicing of the device, a volume above the lid has to be held free of other piping and components. The shape of the service access volume is a cylinder as shown on figure. The measurement of this volume is shown in table below.

Size	h[mm]	Ø[mm]
DN 100	155	250
DN 150	187	315
DN 200	232	400
DN 250	281	500
DN 315	334	630
DN 350	369	710
DN 400	414	800
DN 450	460	900
DN 500	526	1000

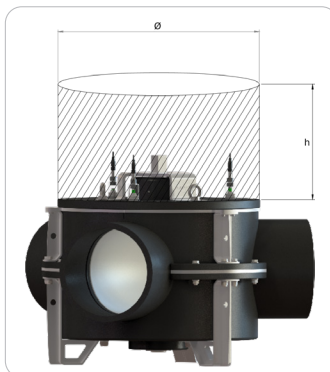

RECOMMENDATION

It is recommended that the product is accessible and is installed in a way that makes it possible to remove the product without impacting the surrounding structure.

SUPPORT

When mounted, the device must be either stand on its feet or be completely supported using the mounting holes in the external reinforcement.

- If floor mounting is chosen it is recommended to bolt the device to the concrete using the mounting holes in the feet.

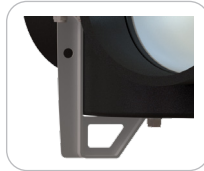

- If the device is to be hung in the air, it must be supported using at least two of the mounting points in the external reinforcements. The supports must be able to fully support the weight of the device without the outlet piping being connected to the rest of the system.

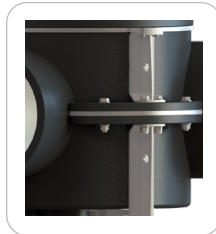

The pipes connected to the device must be completely self-supported even when filled with water, and can't transfer loads into the device.

The design of the piping system also must take heat expansion into account to make sure that expansion of the connected pipe does not exert forces on the device.

MOUNTING INTERFACE

The outlet pipes of the device can be configured from the factory with either straight pipes, DIN flanges, loose DIN flange or ANSI flanges. All in combination with a series of smooth bends.

When connecting the device with the pipe system, only electrofusion, butt-welding and bolted connections are allowed. Do not use extrusion welding as the heat transfer can warp the housing.

AMBIENT CONDITIONS

The device is rated for use in temperature between -25°C & 40°C. If the device is used below freezing temperatures the buildup of stagnant water inside the valve is not allowed as ice formation inside the valve can permanently damage it.

RETROFITTING AN ACTUATOR

If the user wishes to retrofit an actuator, we recommend contacting for technical information on torque requirements and interface measurements. The actuator interface on the device follows ISO 5211.

COMMISSIONING

These steps must be followed closely before first use.

ELECTRICAL CONNECTIONS

Inductive sensors:

The inductive sensors are of the type Balluff BES060U. The supply voltage is 24VDC, and the switch is normally open. The connector has the following pinout:

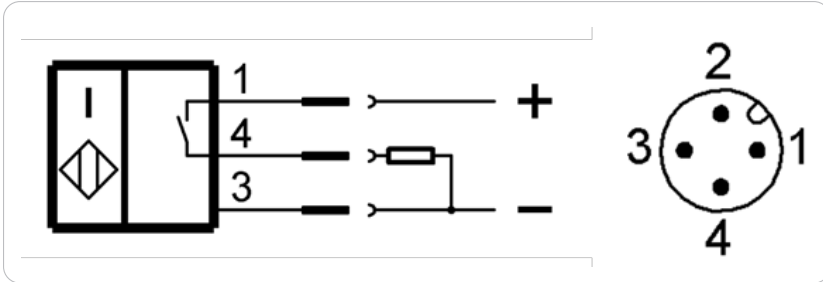

The inductive sensors are meant as a backup signal as the switching point of the sensors are not precise enough for fine positioning.

If the device is ordered with Profinet communication, the network interface on the actuator can be used to transport the signal from the sensors. Contact [for more information](#).

ELECTRICAL ACTUATOR

The unit can be equipped with various types of electric rotary actuators. The wiring diagram for the actuator varies depending on its specifications. Therefore, a wiring diagram and a complete manual are physically included with each rotary actuator. If these documents are lost, please contact Wapro to obtain the documentation again.

To complete commissioning the complete commissioning step in the operation manual specific to the actuator must be completed.

MECHANICAL SETUP

After mounting is completed, use the handwheel to slowly turn the valve from one position to the other. Make sure that there is no sudden resistance to the movement which would indicate a problem. Observe that the mechanical position indicators move smoothly when the end position is reached, and that the mechanical indicators correctly activates the inductive sensors. If problems are encountered, see page 9 and make adjustments until the problem is alleviated, before finishing commissioning.

GENERAL OPERATION

FLOW GUIDE DN 100-DN 150 – MANUAL OPERATION

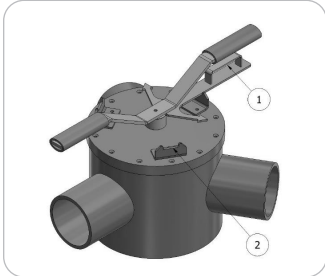

FLOWGUIDES WITH MANUAL HANDLE

Flow Guides size DN 100-DN 150 have manual control handles. When operating, lift the handlebar until the handle (1) is free of the locking bracket (2) and can rotate freely. Turn the handle until the two desired pipes are connected, indicated by the arrows on the handle. The handlebar is released and the handle locks in the locking bracket.

FLOW GUIDE DN 200- DN 500 – MANUAL OPERATION

Sizes DN 200–DN 500 are delivered as standard without manual operation components. Manual operation is possible only when a worm gear with handwheel is installed (available as an optional accessory and can be supplied on request).

When operated manually, the handwheel is rotated to move the core. The core rotates in the same direction as the handwheel; a clockwise rotation of the handwheel results in clockwise movement of the core. The handwheel is turned until the mechanical position indicators pop up, confirming that the desired position has been reached. Please note that correct alignment of the internal pathway is only achieved when the mechanical position indicator reaches the peak of its movement. There are no internal stops in the device, allowing the product to connect any two of the three outlets.

The valve must never be left between positions, as this will block water flow through the valv

FLOW GUIDE DN 200-DN 500 – ELECTRIC OPERATION

Configurations of the valve configured with actuators can be operated electrically using either remote or local controls, or manually using the handwheel on the actuator.

LOCAL ELECTRIC OPERATION

To operate the valve using the selector switch [5] is moved into the “Local” position. Then, depending on the current position, either button [1] or [3] is pressed to make the actuator move to the desired position automatically. The actuator will stop when it has reached its programmed end stop. The movement of the valve can be stopped at any time by using button [2]. At all times the current position of the valve can be seen on the display [6] as well as observing the mechanical position indicators.

REMOTE ELECTRIC OPERATION

To operate the valve remotely the selector switch [5] is moved into the “remote” position. The actuator will no longer react to the local controls and is controlled by the signals sent to it via its connection interface. The precise details of these depend on the configuration of the actuator.

For more information on the connectivity and functionality of the actuator, we refer to the specific operation instructions on the AUMA supplied along with the actuator.

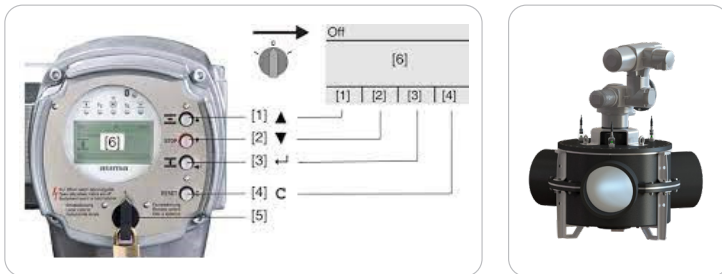

MANUAL OVERRIDE OPERATION

To activate manual override, press the blue button at the center of the handwheel to engage motion. The handwheel is rotated to move the core. The core rotates in the same direction as the handwheel, meaning that clockwise movement of the handwheel results in clockwise movement of the core. The handwheel is rotated until the mechanical position-indicators pop up showing that the desired position has been reached. Note that the correct alignment of the internal pathway is only reached when the mechanical position indicator is at the peak of its movement. Reactivating the electrical movement automatically disengages the manual override.

MAINTENANCE

The following maintenance must be performed for the product to operate as intended. Failing to do so voids the warranty.

MAINTENANCE PLAN

EVERY THREE MONTHS:

- To check for proper function, a full open/close operation must be performed. Long periods without use can cause the gaskets to get stuck in place. The valve should operate smoothly and without sudden resistance. Jerking motion is a sign of sticking gaskets
- Refill both bearing housings with bearing grease using the grease nipples. SKF LGWA 2/0.4 or similar is recommended for 0-40°C. For temperatures below freezing a lower viscosity grease is recommended

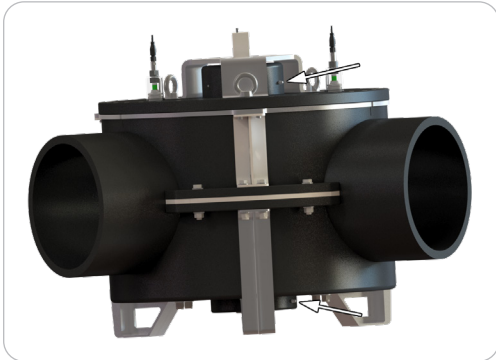

- Inspect the device for visual signs of damage. If any significant damage is found, please contact [\[redacted\]](#) for advice

EVERY 5.000 MOVEMENTS:

If supplied with AUMA actuator, the actuator has an internal movement counter to keep track of movements.

- The mechanical position indicators should be taken apart to inspect for wear on the indicator (if equipped). See maintenance guide on the following pages for instructions. If the indicators show sign of wear the indicators should be adjusted accordingly. If the indicators are worn beyond the range of adjustment range of the indicators, the indicator piston should be changed out
- The gaskets should be inspected for wear or tears. This can either be done using a camera sent through the pipe system or by disassembling the valve to its service state (Described on the following pages)

MAINTENANCE INSTRUCTIONS

INSPECTION OF MECHANICAL POSITION INDICATOR (DN 200-DN 500)

Before performing these steps ensure that the valve is perfectly at one of the end positions, shown by the indicator piston being all the way at the top of its movement.

Note that this service must be done while the valve is not under pressure.

1. Disconnect the connector from the inductive sensor (if equipped)
2. Unscrew the inspection glass from the lid
3. Loosen the piston retaining nut (the lower of the two spanner surfaces) using a 30mm spanner. Then carefully remove it. Please note that this will release the force from the piston return spring
4. Remove the spring
5. Gently pull up on the indicator piston. It should move freely with only the resistance from its O-rings
6. Inspect the tip of the piston for wear
7. If the piston shows signs of wear, go to the "readjusting mechanical position indicators" chapter of this guide. Otherwise reassemble the indicator. Reassembly is the opposite of disassembly
8. Perform these actions for all three indicators



READJUSTING MECHANICAL POSITION INDICATORS (DN 200-DN 500)

Before performing these steps ensure that the valve is perfectly at one of the end positions, shown by the indicator piston being all the way at the top of its movement.

1. Disconnect the connector from the inductive sensor (if equipped)
2. Unscrew the inspection glass from the lid
3. Loosen the adjustment counter nut (the upper of the two spanner surfaces) using a 30mm spanner
4. Adjust the adjustment screw using a 17mm spanner until the top of the adjustment nut perfectly matches with the place the indicator goes from red to green
5. Retighten the adjustment counter nut while using a spanner to keep the adjustment screw from turning
6. Reassembly is the opposite of disassembly

CHANGING INTERNAL GASKETS (DN 100-DN 150)

Note that this service must be done while the valve is not under pressure.

This procedure can damage the internal shaft seals in the lid if not done carefully. It is recommended to change these when performing this procedure, to keep water from leaking from the lid.

1. Loosen the hex set screw in the handle and remove it
2. Use a pen or pointy object to mark the lid and housing to ensure that the lid is mounted in the same position during reassembly
3. Loosen the countersunk hex screws all the way around the edge of the lid
4. Remove the lid. Please lift straight upwards to reduce the risks of the shaft seals being damaged
5. Gently lift the core out of the housing
6. With the core removed from the housing the gaskets can now be inspected or changed. When mounting new gaskets, use a rubber mallet to seat them into their pocket
7. This is the time to change the 2 internal shaft seals, located in the bottom of the lid. The new seals are carefully hammered down using a rubber mallet. Be careful not to warp the seals
8. Reassembly is the opposite of assembly. The screws in the lid are retightened using an electric screwdriver set to 5Nm

CHANGING INTERNAL GASKETS (DN 200-DN 250)

Note that this service must be done while the valve is not under pressure.

This procedure can damage the internal shaft seals in the lid if not done carefully. It is recommended to change these when performing this procedure, to keep water from leaking from the lid.

1. Remove the 4 bolts fastening the gearbox to the gearbox bracket
2. Gently remove the gearbox. It might require a few taps with a rubber mallet to come loose
3. Loosen the hex set screw in the gearbox adapter and remove it
4. Loosen the countersunk hex screws that fasten the gearbox bracket to the lid
5. Loosen the hex set screw that fasten the allows to the shaft and remove the arrows
6. Use a pen of pointy object to mark the lid and housing to ensure that the lid is mounted in the same position during reassembly
7. Loosen the countersunk hex screws all the way around the edge of the lid
8. Remove the lid. Please lift straight upwards to reduce the risks of the shaft seals being damaged
9. Gently lift the core out of the housing
10. With the core removed from the housing the gaskets can now be inspected or changed. When mounting new gaskets, use a rubber mallet to seat them into their pocket
11. This is the time to change the 2 internal shaft seals, located in the bottom of the lid. The new seals are carefully hammered down using a rubber mallet. Be careful not to warp the seals
12. Reassembly is the opposite of assembly. The screws in the lid are retightened using a torque wrench set to 7Nm

CHANGING INTERNAL GASKETS (DN 315-DN 500)

Note that this service must be done while the valve is not under pressure.

This procedure can damage the internal shaft seals in the bottom of the housing if not done carefully. It is recommended to change these when performing this procedure, to keep water from intruding into the lower bearing housing if the gaskets are damaged.

1. Loosen the 6 sleeve nuts fastening the lid of the bottom bearing housing
2. Gently remove the ball bearing along with the small spacer ring
3. Loosen the 2 Allen head Hex screws holding together the clamp on the shaft and carefully remove it. Note that the axial ball bearing will be loose and will come out along with the clamp
4. Use a pen of pointy object to mark the lid and housing to ensure that the lid is mounted in the same position during reassembly
5. Loosen the countersunk hex screws all the way around the edge of the lid
6. The entire moving assembly of the valve can now be removed by lifting on the lifting eyes in the lid of the valve. Please lift straight upwards to reduce the risks of the shaft seals being damaged. Note that the removed assembly contains most of the weight of the product. Be careful when lifting and maneuvering
7. With the moving assembly removed from the housing the gaskets can now be inspected or changed. When mounting new gaskets, use a rubber mallet to seat them into their pocket
8. This is the time to change the 2 internal shaft seals, located in the bottom of the housing. The new seals are carefully hammered down using a rubber mallet. Be careful not to warp the seals
9. Reassembly is the opposite of assembly. The screws in the lid are retightened using a torque wrench set to 7Nm

TECHNICAL INFO

PRESSURE RATING:
Water pressure: 1,5 bar
Vacuum: 0,7 bar

LEAKAGE RATING:
Less than 1% of leakage allowed by EN 19569-4 Class 5.

OPERATING TEMPERATURE:
-25°C - 40°C

PRESSURE LOSS:
DN 200: $v=3\text{m/s}$ $V=260\text{m}^3/\text{h}$ Pressure loss: 620Pa
DN 250: $v=3\text{m/s}$ $V=410\text{m}^3/\text{h}$ Pressure loss: 618Pa
DN 315: $v=3\text{m/s}$ $V=650\text{m}^3/\text{h}$ Pressure loss: 613 Pa
DN 400: $v=3\text{m/s}$ $V=1150\text{m}^3/\text{h}$ Pressure loss: 610 Pa
DN 500: $v=3\text{m/s}$ $V=1800\text{m}^3/\text{h}$ Pressure loss: 608 Pa

VELOCITY CURVES:

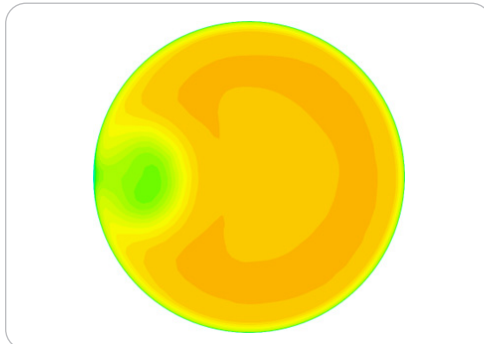
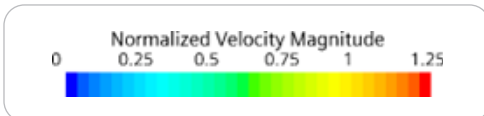
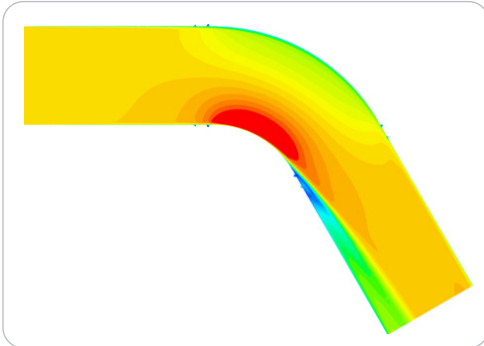

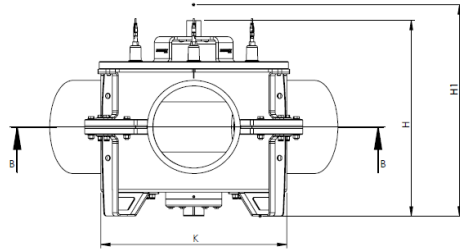
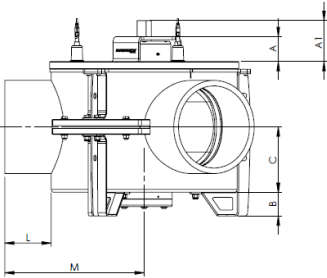
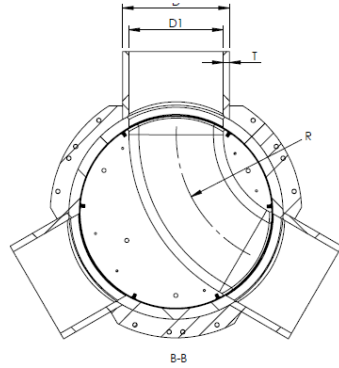
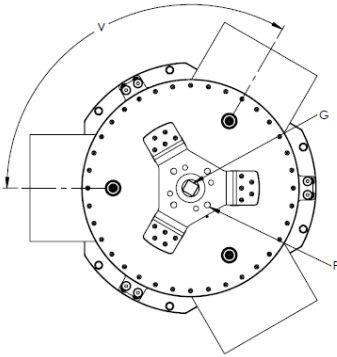

DIMENSIONS [MM] AND KOLUMN F [MM, ACCORDING TO ISO 5211]

Sizes	A	AI	B	C	D	D1	F	G	H	HI
DN 100	-	-	-	107	Ø110	Ø96,8	-	-	315	-
DN 150	-	-	-	124	Ø160	Ø141	-	-	365	-
DN 200	100	132	-	147	Ø200	Ø176.2	F10	22x22	435	Upon request
DN 250	100	132	-	176	Ø250	Ø220.4	F10	22x22	493	Upon request
DN 315	90	139	80	221	Ø315	Ø277.6	F12 + F14	36x36	661	Upon request
DN 350	90	139	80	246	Ø355	Ø312.8	F12 + F14	36x36	710	Upon request
DN 400	90	139	80	251	Ø400	Ø369.4	F12 + F14	36x36	730	Upon request
DN 450	90	139	80	288	Ø450	Ø415.6	F12 + F14	36x36	800	Upon request
DN 500	90	139	80	325	Ø500	Ø461.8	F12 + F14	36x36	870	Upon request

Sizes	K	L	M	R	T	V
DN 100	Ø250	100	225	145	6,6 (SDR 17)	120 °
DN 150	Ø315	110	268	200	9,5 (SDR 17)	120 °
DN 200	Ø400	135	335	200	11,9 (SDR 17)	120 °
DN 250	Ø500	180	430	300	14,8 (SDR 17)	120 °
DN 315	Ø630	160	473	400	18,7 (SDR 17)	120 °
DN 350	Ø710	175	530	500	21,1 (SDR 17)	120 °
DN 400	Ø800	200	600	520	15,3 (SDR 26)	120 °
DN 450	Ø900	230	680	625	17,2 (SDR 26)	120 °
DN 500	Ø1000	260	760	735	19,1 (SDR 26)	120 °

CONGRATULATIONS ON YOUR PURCHASE OF FLOW GUIDE 3-WAY VALVE

The unique construction of the Flow Guide three-way valve allows for smooth transport of live fish, as well as a convenient way of controlling the direction of transport. Eliminating the use of multiple traditional valves for flow direction control.

RECYCLING

The Flow Guide is made mainly from environmentally friendly materials. When decommissioning, remove the valve and separate the parts for recycling.

MATERIALE SPECIFIKATION

HOUSE	PEHD 100
LID	PEHD 500
CORE	PEHD 500
GASKET IN CORE	Silicone
GASKET IN LID	EPDM
OIL SEAL	NBR / 316 Stainless steel
STEEL	316 Stainless steel
BOLTS AND SCREWS	316 Stainless steel
GEARBOX	Lacquered cast iron / 316 Stainless steel
HANDWEEL	Lacquered zinc
DISC BY HANDWEEL	Nylon

WAPRO A/S WARRANTY

Wapro is going to alleviate fault in the material or manufacturing on a new Flow Guide three-way valve for a period of two (2) years from the documented purchase date, if the valve has been used according to Wapros inductions and recommendations, and under normal use cases. The warranty does not cover damages to the valve from external mechanical forces, such as from people, animals, or heavy machinery, or from external forces from the surrounding structure or system. The warranty does not apply if the valve has been modified or changed in any way after its manufacture. Furthermore, the warranty is not valid if (a) the valve is damaged due to exposure to high concentrations of chemicals, or (b) if the valve is damaged because of pressure spikes, water hammering or vacuums exceeding the rated limits, or (c) the vacuum exerted on the valve exceeds 0,7 bar or the pressure exerted exceeds 1,5 bar.



CONTACT WAPRO

customerservice@wapro.com

wapro.com

SE: +46 (0)454 185 10

DK: +45 64 82 40 00

US: +1 888 927 8677

UK: +44 114 308 0123

DE: +49 541 963 24144

Rev 1.5